



STEEL TRENCH PRODUCTS



Who is GME?

As an industry pioneer since the 1960's, GME quickly took a leadership position in product design and industry development. Since the beginning, GME has lead the industry in product development, innovation and effectiveness.

GME is the producer of the world's most complete line of trench shoring and shielding equipment. The products we offer include:

- Site Access & Site Safety
- Hydraulic Shoring
- Steel Trench Shields
- Aluminum Trench Shields
- Modular Aluminum Trench Shields (Lite-Shield™)
- Slide Rail Shoring Systems
- Hydraulic Bracing Systems (MD Brace)

Through our extensive distribution network, our products can be found on a countless number of job sites around the globe.

Our original facility in Union City, Michigan has expanded over the years to meet the growth demands of the industry. Currently we have three plants dedicated to trench shield and trench shoring production, three located in Union City, Michigan. GME has a sales force that offers over 100 years of collective experience in the trench shoring and shielding industry. With this combined knowledge, GME is able to provide our customers with the solutions they need to get their projects completed.

With a dedicated Research and Development team, including an in-house Registered Professional Engineer, GME is able to continually improve upon our products and product selection, proving that GME is the industry leader in product innovation.

If you have an upcoming project and would like to see how GME can assist you, or if you would like more information about GME and our products, please feel free to contact us at 800.248.2054 or on the web at www.gme-shields.com.



Steel Trench Products

What are Steel Trench Products? Why use them and where to use them?

What is a Steel Trench Product?

A Steel Trench Product is a product that is used for worker protection during underground excavation. Commonly referred to as Trench Boxes or Trench Shields, these products do not actively exert forces upon the sidewalls of an excavation, the way a shoring system would. They are passive, engineered systems that are designed to withstand the pressures exerted upon them. These products include: Steel Trench Shields, Height Adapters, Spreader Pipe, Manhole Shields and Overlap Sheet Pile.



A 6M Series Trench Shield with Height Adapters

Why use Steel Trench Products?

The reasons to use a Steel Trench Product are numerous. With that said, here are a few:

- Provide workers with a safe working environment.
- Increases production. Enables workers to focus on their jobs, instead of worrying about site conditions.
- Saves Money. The use of a Steel Trench Product can save the cost of site restoration by limiting the amount of backfill needed.
- OSHA Compliant. Properly using a Steel Trench Product can be the difference between getting an OSHA fine or not getting one.
- Saves Time. A Steel Trench Product can reduce the amount of down time on machines and increase crew productivity.



Stacked Trench Shields

Where to use Steel Trench Products?

Steel Trench Products can be found on a variety of job projects. These projects include:

- Pipeline
- Jack and Bore
- Cast-in-Place
- Large diameter pipe/vaults
- Sewer/Water repair & installations
- Municipal work
- And many more



Round Manhole Shield

Standard Features



Standard Features

The standard features of all the GME Steel Trench Shields are anything but standard in quality, performance and durability. Designed with the end-user in mind, the GME Steel Trench Shields feature a number of standard features that not only increase the usability of the trench shield, but increase job-site safety, without added costs.



Job-Matched Options

The Job-Matched Options on GME trench shields enable each and every steel trench shield to be customized to a specific job or need.

Job-Matched Options

- Adjustable collars (on 3m and 4" trench shields only)
- Bottom stacking tubes (on no knife edge shields)
- End panels (for 3- and 4-sided applications)
- Floating collar set (excellent for Jack & Bore projects)
- Foam filler (reduces excess weight build-up from water and soil)
- Front lowered collars
- Heavy-duty collars (7" O.D. x 1" thick)
- Height Adapters
- No knife edge (flat bottom)
- Pit kits (4-sided)
- Pulling eyes
- Pushing pads
- Tied spreaders (connected by vertical pieces, recommended for spreaders over 60")
- Top angle cap



Adjustable Collars



Pulling eyes



Pushing Pads

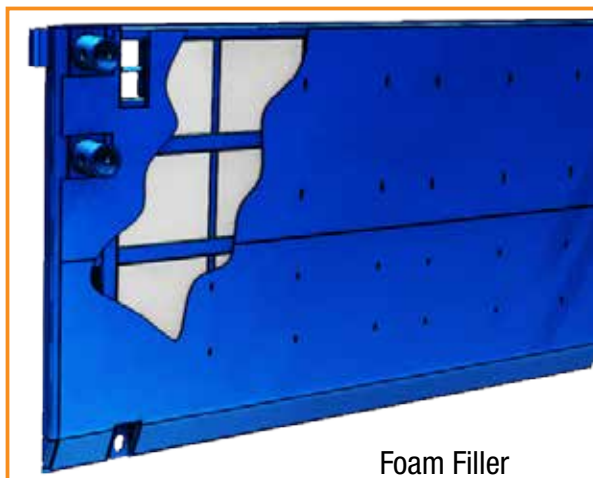

Foam Filler

8" Wall Trench Shields



8M Series

The standard version of the 8" wall trench shields, the 8M Series is a non-rigid design with strategic reinforcements, providing workers protection on some of the most demanding job-sites. Offering users excellent depth ratings while providing exceptional vertical pipe clearance. The 8M Series can be set up in a 4- or 5-collar configuration to meet the needs of most any job-site while providing a safe and productive working environment. Ideal for use with machine over 80,000 pounds. 8M Series shields use 8DS (8" Sch 80) spreaders.



Model	Size		Pipe Clearance	Weight (lbs.)	Shield Cap (PSF)*	Maximum Depth per Soil Type (ft.)*			
	H	L				A	B	C-60	C-80
8M416	4'	16'	16"	5538	2729	99	63	47	36
8M420	4'	20'	16"	6578	1684	69	39	30	23
8M424	4'	24'	16"	7595	1142	48	27	21	16
8M428	4'	28'	16"	8608	825	35	20	16	12
8M430	4'	30'	16"	9114	714	31	18	14	11
8M616	6'	16'	40"	7310	2931	99	68	52	40
8M620	6'	20'	40"	8774	1809	75	43	33	26
8M624	6'	24'	40"	10199	1227	52	30	23	18
8M628	6'	28'	40"	11614	887	38	23	18	14
8M630	6'	30'	40"	12322	767	34	20	16	13
8M816	8'	16'	64"	9135	2387	99	57	44	34
8M820	8'	20'	64"	11022	1873	79	46	35	27
8M824	8'	24'	64"	12854	1270	55	32	25	20
8M828	8'	28'	64"	14673	918	41	24	19	15
8M830	8'	30'	64"	15582	794	36	22	17	14
8M1016	10'	16'	76"	10959	2109	89	52	40	31
8M1020	10'	20'	76"	13271	1687	72	42	33	26
8M1024	10'	24'	76"	15510	1296	57	34	27	21
8M1028	10'	28'	76"	17731	937	42	26	21	17
8M1030	10'	30'	76"	18842	810	37	23	19	15

Additional sizes are also available

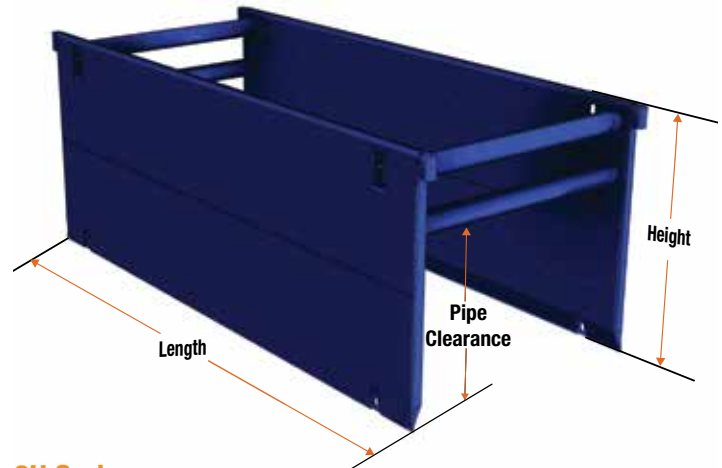

8H Series

Designed from the 8M Series, the 8H Series provides users the extra depth needed for those tough, demanding projects while not sacrificing an inch of vertical pipe clearance!

Meant for use on only the toughest of job-sites, the 8H Series is designed for use with excavators in the 100,000+ pound range. 8H Series shields use 8DS (8" Sch 80) spreaders.

Model	Size		Pipe Clearance	Weight (lbs.)	Shield Cap (PSF)*	Maximum Depth per Soil Type (ft.)*			
	H	L				A	B	C-60	C-80
8H416	4'	16'	16"	6161	3426	99	78	59	45
8H420	4'	20'	16"	7359	2310	94	53	41	31
8H424	4'	24'	16"	8535	1567	64	37	28	22
8H428	4'	28'	16"	9706	1132	47	27	21	16
8H430	4'	30'	16"	10291	980	41	24	18	14
8H616	6'	16'	40"	8255	3731	99	86	65	50
8H620	6'	20'	40"	9959	2496	99	58	45	34
8H624	6'	24'	40"	11623	1693	71	41	31	24
8H628	6'	28'	40"	13279	1223	52	30	23	18
8H630	6'	30'	40"	14106	1058	45	27	21	16
8H816	8'	16'	64"	10401	2387	99	57	44	34
8H820	8'	20'	64"	12610	1910	80	46	36	28
8H824	8'	24'	64"	14764	1591	68	39	31	24
8H828	8'	28'	64"	16904	1269	55	32	25	20
8H830	8'	30'	64"	17974	1098	48	28	22	18
8H1016	10'	16'	76"	12547	2371	99	58	45	35
8H1020	10'	20'	76"	15262	1897	81	47	37	29
8H1024	10'	24'	76"	17904	1581	68	40	31	25
8H1028	10'	28'	76"	20528	1297	57	34	27	21
8H1030	10'	30'	76"	21841	1122	50	30	24	19

Additional sizes are also available

6" Wall Trench Shields

6M Series

The work horse of the trench shield industry, the 6M Series offers end-users an excellent depth rating, while still keeping the weight at a manageable level. The 6M Series is one of the best ways to save money on excavation cost while providing workers with the peace of mind that they are protected. Enabling them to focus on production.

The 6M Series is designed to be used with excavators with the 50,000 to 80,000 pound range. 6M Series shields use 8DS (8" Sch 80) spreaders.



Model	Size		Pipe Clearance	Weight (lbs.)	Shield Cap (PSF)*	Maximum Depth per Soil Type (ft.)*			
	H	L				A	B	C-60	C-80
6M416	4'	16'	16"	4975	2073	85	48	37	28
6M420	4'	20'	16"	5936	1280	53	30	23	18
6M424	4'	24'	16"	6873	868	37	21	16	13
6M428	4'	28'	16"	7804	627	27	16	12	10
6M616	6'	16'	40"	6612	2195	91	52	40	30
6M620	6'	20'	40"	7976	1355	57	33	26	20
6M624	6'	24'	40"	9300	919	40	23	18	14
6M628	6'	28'	40"	9957	776	34	20	16	13
6M630	6'	30'	40"	10613	664	30	18	14	11
6M816	8'	16'	64"	8300	2168	91	52	40	31
6M820	8'	20'	64"	10068	1393	60	35	27	21
6M824	8'	24'	64"	1178	945	42	25	20	16
6M828	8'	28'	64"	12626	798	36	22	17	14
6M830	8'	30'	64"	13474	983	31	19	15	13
6M1016	10'	16'	76"	9989	1537	66	39	31	24
6M1020	10'	20'	76"	12160	1230	54	32	25	20
6M1024	10'	24'	76"	14257	960	43	26	21	17
6M1028	10'	28'	76"	15296	811	37	23	19	15
6M1030	10'	30'	76"	16335	694	33	20	17	14

Additional sizes are also available



6H Series

The 6H Series is designed from the 6M Series, providing users the extra depth needed for those tough, demanding projects while not sacrificing an inch of vertical pipe clearance!

Meant for use on jobs that require more depth than a 6M Series, the 6H Series fills the need. Designed for use with excavators within the 60,000 to 80,000 pound range. 6H Series shields use 8DS (8" Sch 80) spreaders.

Model	Size		Pipe Clearance	Weight (lbs.)	Shield Cap (PSF)*	Maximum Depth per Soil Type (ft.)*			
	H	L				A	B	C-60	C-80
6H416	4'	16'	16"	5598	2627	99	60	46	35
6H420	4'	20'	16"	6717	1774	73	41	32	24
6H424	4'	24'	16"	7812	1203	50	29	22	17
6H428	4'	28'	16"	8902	869	37	21	16	13
6H616	6'	16'	40"	7556	2824	99	66	50	38
6H620	6'	20'	40"	9161	1885	78	45	34	27
6H624	6'	24'	40"	10724	1279	54	31	24	19
6H628	6'	28'	40"	11501	1080	46	27	21	16
6H630	6'	30'	40"	12277	924	40	24	18	15
6H816	8'	16'	64"	9566	2387	99	57	44	34
6H820	8'	20'	64"	11656	1910	80	46	36	28
6H824	8'	24'	64"	13687	1317	57	33	26	20
6H828	8'	28'	64"	14696	1112	48	29	23	18
6H830	8'	30'	64"	15705	952	42	25	20	16
6H1016	10'	16'	76"	11576	2129	90	52	40	32
6H1020	10'	20'	76"	14151	1704	73	43	33	26
6H1024	10'	24'	76"	16651	1340	59	35	27	22
6H1028	10'	28'	76"	17891	1132	50	30	24	19
6H1030	10'	30'	76"	19132	968	44	27	21	17

Additional sizes are also available

*PSF (pounds per square foot) ratings indicate maximum shield capacities. Depths are based on A, B, C and C-80 soil types as described in O.S.H.A.'s 29 CFR Part 1926 Subpart P, October 31, 1989 with Type A not exceeding 25 PSF per foot of depth, Type B not exceeding 45 PSF per foot of depth, Type C not exceeding 60 PSF per foot of depth and Type C-80 not exceeding 80 PSF per foot of depth. Determine actual soil pressure and consult manufacturers Tabulated Data prior to each use.

4" Wall Trench Shields



4L Series

The combination of narrow sidewalls, relative light-weight construction and good depth ratings, these 4" trench shields can save money, time, and lives.

The 4L Series offers a single wall and a double wall version, standard heights range from 4' to 8', with lengths from 6' to 20', providing up to 48" of vertical pipe clearance. These 4" trench shields are perfectly suited for excavators in the 40,000 lb. to 50,000 lb. range. 4L Series shields use 5DS (5" Sch 80) spreaders.



Model	Size		Pipe Clearance	Weight (lbs.)	Shield Cap (PSF)*	Maximum Depth per Soil Type (ft.)*			
	H	L				A	B	C-60	C-80
SINGLE-WALL									
4L46SW	4'	6'	16"	1776	3319	99	76	57	43
4L48SW	4'	8'	16"	2044	1517	63	36	27	21
4L410SW	4'	10'	16"	2312	908	38	22	17	13
4L412SW	4'	12'	16"	2556	604	26	15	12	10
4L66SW	6'	6'	40"	2135	1627	68	39	30	23
4L68SW	6'	8'	40"	2505	1250	53	31	24	19
4L610SW	6'	10'	40"	2881	870	38	22	17	14
4L612SW	6'	12'	40"	3218	578	26	16	13	10
4L86SW	8'	6'	48"	2525	1165	51	30	23	19
4L88SW	8'	8'	48"	3004	919	41	24	19	15
4L810SW	8'	10'	48"	3487	735	33	20	16	13
4L812SW	8'	12'	48"	3917	565	27	17	13	11
DOUBLE-WALL									
4L410	4'	10'	16"	2576	1662	68	39	30	23
4L412	4'	12'	16"	2874	1385	57	33	25	19
4L414	4'	14'	16"	3172	1187	49	28	22	17
4L416	4'	16'	16"	3470	906	38	22	17	13
4L610	6'	10'	40"	3343	1733	72	42	32	25
4L612	6'	12'	40"	3775	1444	61	35	27	21
4L614	6'	14'	40"	4206	1238	53	31	24	18
4L616	6'	16'	40"	4638	938	41	24	19	15
4L810	8'	10'	48"	4149	1770	75	43	33	26
4L812	8'	12'	48"	4714	1475	63	37	29	22
4L814	8'	14'	48"	5280	1264	55	32	25	20
4L816	8'	16'	48"	5845	954	42	25	20	16
4L820	8'	20'	48"	6976	592	28	17	14	11

Model	Size		Pipe Clearance	Weight (lbs.)	Shield Cap (PSF)*	Maximum Depth per Soil Type (ft.)*			
	H	L				A	B	C-60	C-80
4M412	4'	12'	16"	3501	2575	99	59	45	34
4M416	4'	16'	16"	4318	1418	59	34	26	20
4M420	4'	20'	16"	5160	876	37	21	17	13
4M424	4'	24'	16"	5984	569	25	15	11	9
4M612	6'	12'	40"	4622	2696	99	63	48	37
4M616	6'	16'	40"	5788	1473	62	36	28	21
4M620	6'	20'	40"	6993	909	39	23	18	14
4M624	6'	24'	40"	8170	579	26	16	13	10
4M812	8'	12'	64"	5787	1868	79	46	35	27
4M816	8'	16'	64"	7302	1401	60	35	27	22
4M820	8'	20'	64"	8871	926	41	25	19	16
4M824	8'	24'	64"	10401	583	27	17	14	11
4M1016	10'	16'	76"	8817	994	45	27	22	17
4M1020	10'	20'	76"	10749	795	37	23	18	15
4M1024	10'	24'	76"	12633	586	28	18	15	12

Additional sizes are also available

4M Series

The 4" wall series of trench shields are the standard of the trench shield industry. With the combination of narrow sidewalls, relative light-weight construction and good depth ratings, these 4" trench shields can save money, time, and lives.

The 4M Series, standard height range from 4' to 10' with lengths exceeding 24', while providing up to 76" of vertical pipe clearance. 4M trench shields are perfectly suited for excavators in the 40,000 lb. to 60,000 lb. range. 4M Series shields use the 8DS (8" Sch 80) spreaders.

Job site photos are strictly intended for general product information only and may not comply with all applicable safety standards. Always refer to manufacturers' specific tabulated data, O.S.H.A. 29 CFR 1926 Subpart P for excavations, and all applicable safety standards prior to each use.

3" Wall Trench Shields

3L Series

The 3" trench shields are designed with plumbing, utility, and municipality works in mind. These shields are lightweight and provide protection for the shallow depths required for light-duty repair work.

The 3L series is designed to use 3" x 3" tubes as spreaders (3SQ), keeping the weight low to allow smaller machines to install and remove the trench shield. The 3L is ideal for use with rubber tired backhoes. 3L Series shields use 3SQ (3" square tubes) spreaders.



Model	Size		Pipe Clearance	Weight (lbs.)	Shield Cap (PSF)*	Maximum Depth per Soil Type (ft.)*			
	H	L				A	B	C-60	C-80
3L46	4'	6'	24"	673	1142	48	27	21	16
3L48	4'	8'	24"	835	827	35	20	16	12
3L410	4'	10'	24"	996	523	23	14	11	9
3L412	4'	12'	24"	1158	360	16	10	8	6
3L66	6'	6'	24"	921	1244	53	31	24	19
3L68	6'	8'	24"	1151	742	33	19	15	12
3L610	6'	10'	24"	1381	469	22	13	11	9
3L612	6'	12'	24"	1611	323	16	10	8	7
3L86	8'	6'	24"	1169	1125	49	29	23	18
3L88	8'	8'	24"	1467	699	32	20	16	13
3L810	8'	10'	24"	1766	442	22	14	11	10
3L812	8'	12'	24"	2064	304	16	11	9	8

Additional sizes are also available

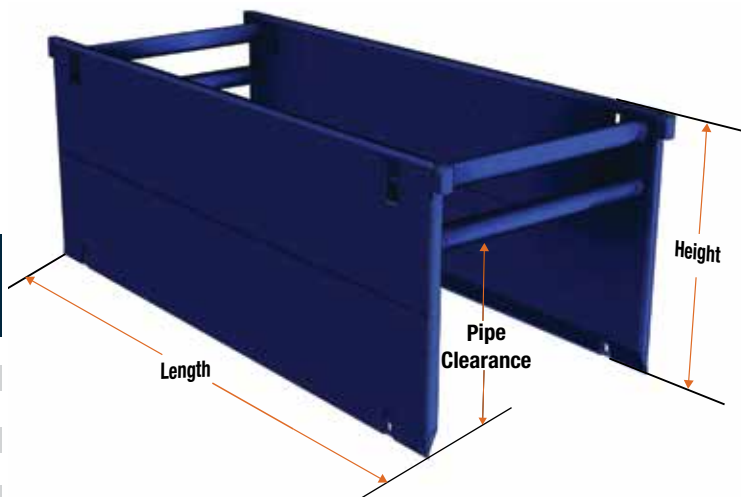

Model	Size		Pipe Clearance	Weight (lbs.)	Shield Cap (PSF)*	Maximum Depth per Soil Type (ft.)*			
	H	L				A	B	C-60	C-80
SINGLE-WALL									
3M46SW	4'	6'	24"	831	1959	80	46	35	26
3M48SW	4'	8'	24"	1030	1118	47	24	21	16
3M410SW	4'	10'	24"	1228	676	29	17	13	10
3M412SW	4'	12'	24"	1427	453	20	12	10	8
3M66SW	6'	6'	38"	1113	1766	74	42	32	25
3M68SW	6'	8'	38"	1380	981	42	25	19	15
3M610SW	6'	10'	38"	1647	594	27	16	13	10
3M612SW	6'	12'	38"	1614	397	19	12	10	8
3M86SW	8'	6'	51"	1409	1033	45	27	21	17
3M88SW	8'	8'	51"	1745	775	35	21	17	14
3M810SW	8'	10'	51"	2080	551	26	16	13	11
3M812SW	8'	12'	51"	2415	369	19	12	10	9
DOUBLE-WALL									
3M68DW	6'	8'	38"	1772	1643	69	40	30	24
3M610DW	6'	10'	38"	2140	1314	56	32	25	19
3M612DW	6'	12'	38"	2508	1015	44	26	20	16
3M88DW	8'	8'	51"	2295	1226	53	31	24	19
3M810DW	8'	10'	51"	2772	981	43	26	20	16
3M812DW	8'	12'	51"	3249	817	37	22	18	14

Additional sizes are also available

3M Series

Similar to the 3L Series, the 3M trench shields are designed for use with plumbing, utility, and municipality work in mind.

Meant for use on jobs that require more depth than a 3L Series, 3M Series fills the need by providing up to 51" of vertical pipe clearance. Designed for use with rubber tired backhoes and excavators up to 30,000 to 50,000 pound range. 3M Series shields use the 5DS (5" Sch 80) spreaders.

*PSF (pounds per square foot) ratings indicate maximum shield capacities. Depths are based on A, B, C and C-80 soil types as described in O.S.H.A.'s 29 CFR Part 1926 Subpart P, October 31, 1989 with Type A not exceeding 25 PSF per foot of depth, Type B not exceeding 45 PSF per foot of depth, Type C not exceeding 60 PSF per foot of depth and Type C-80 not exceeding 80 PSF per foot of depth. Determine actual soil pressure and consult manufactures Tabulated Data prior to each use.

Manhole Trench Shields



MH Series

The square manhole trench shield configuration provides the needed inside clear span while reducing the amount of excavation and restoration required. The Manhole Trench Shield is built off the same rugged frame as a 4M trench shield. Cut-outs and replaceable doors are available.

The MH Series is designed to use 5" Sch. 80 (5DS) connected spreaders which are included with the shields and provide up to 45" of vertical pipe clearance. The MH Series is suited for 40,000 lb. to 60,000 lb. excavators.

Optional cut-out sizes available:
24" x 24" & 36" x 36"



Model	Size			Pipe Clearance	Weight (lbs.)	Shield Cap (PSF)*	Maximum Depth per Soil Type (ft.)*			
	H	W	L				A	B	C-60	C-80
SINGLE-WALL										
MH8SW	8'	8'	8'	45"	3717	655	30	19	15	12
MH10SW	8'	10'	10'	45"	4270	426	21	13	11	9
MH48SW	4'	8'	8'	N/A	2533	844	37	22	17	13
MH410SW	4'	10'	10'	N/A	2920	575	25	15	12	9
DOUBLE-WALL										
MH8DW	8'	8'	8'	45"	4387	2160	90	52	40	31
MH10DW	8'	10'	10'	45"	5084	1641	70	40	31	25
MH12DW	8'	12'	12'	45"	5781	1297	56	33	26	20
MH48DW	4'	8'	8'	N/A	2866	2160	88	50	38	29
MH410DW	4'	10'	10'	N/A	3332	1813	75	42	32	25
MH412DW	4'	12'	12'	N/A	3999	1347	56	32	24	19
DOUBLE-WALL WITH CUT-OUTS										
MH8DW w/CO	8'	8'	8'	45"	4387	1924	81	47	36	28
MH10DW w/CO	8'	10'	10'	45"	5084	1252	54	32	25	20
MH12DW w/CO	8'	12'	12'	45"	5781	879	39	24	19	15

Additional sizes are also available



Model	Size		Weight (lbs.)	Shield Cap (PSF)*	Maximum Depth per Soil Type (ft.)*			
	Dia.	H			A	B	C-60	C-80
RMH 8.5 x 4	8.5'	4'	920	1920	32	32	32	21
RMH 8.5 x 8	8.5'	8'	1609	1920	32	32	32	21
RMH 10 x 4	10'	4'	1100	1862	32	32	32	21
RMH 10 x 8	10'	8'	1969	1862	32	32	32	21
RMH 8.5 x 8 w/RC	8.5'	8'	2319	1649	25	25	25	17
RMH 10 x 8 w/RC	10'	8'	2675	1649	25	25	25	17

Additional sizes are also available

Optional Replaceable cut-out (RC) sizes:

RMH 8.5 x 8 w/RC - Two (2) 55" w x 40" h, One (1) 29" w x 24" h
 RMH 10 x 8 w/RC - Two (2) 72" w x 48" h, One (1) 41" w x 30" h

RMH Series

Specially designed for personal protection during manhole installations and repair work, the Round Manhole Shields feature high strength corrugated steel walls with reinforced top and bottom rings.

Optional cut-outs and replaceable doors are available as are adjustable leg kits. Round Manhole Shields are designed to be used with rubber tired backhoes.

Job site photos are strictly intended for general product information only and may not comply with all applicable safety standards. Always refer to manufacturers' specific tabulated data, O.S.H.A. 29 CFR 1926 Subpart P for excavations, and all applicable safety standards prior to each use.

Manhole Trench Shields

Octagon Manhole

GME Octagon Shields are 8-sided, all-welded, and pre-assembled. They are ideal for contractors, municipal water and sewer departments, plumbers, and all types of utility contractors who are engaged in routine water main or gas-line repairs and maintenance work.

Featuring cutouts with bolt-on doors on four sides, allowing clearance and access to junctions and crossing lines. The all-steel construction offers strength, and the single wall design keeps the weight low. Designed for use with excavators in the 40,000 lb. to 60,000 lb. range.

Model	Size			Trapezoid Door Size Height x Top x Bottom	Weight (lbs.)	Maximum Depth per Soil Type (ft.)*			
	H	W	L			A	B	C-60	C-80
OCT 488	4'	8'	8'	No Doors	2450	88	50	38	29
OCT 688	6'	8'	8'	18" x 23" x 38"	3500	79	45	35	27
OCT 888	8'	8'	8'	23" x 23" x 42"	4652	76	44	34	26
OCT 41010	4'	10'	10'	No Doors	3152	60	34	26	20
OCT 61010	6'	10'	10'	18" x 23" x 38"	4485	53	31	24	19
OCT 81010	8'	10'	10'	23" x 23" x 66"	5252	52	31	24	19
OCT 41212	4'	12'	12'	No Doors	4094	30	30	23	17
OCT 81212	8'	12'	12'	48" x 48" x 72"	7100	30	30	23	17



WTB Series

Tap Boxes are a 4-sided, all-welded, preassembled trench shield system. Ideal for crews who routinely do water main repairs and maintenance. The WTB Series can be built as a 3" or 4" wall trench shield that features 24" x 24" cutouts and doors (larger cutouts are available) on all sides, allowing for lines coming into and out of the work area.

Designed for use with rubber tired backhoes and excavators up to the 50,000 pound range.

*PSF (pounds per square foot) ratings indicate maximum shield capacities. Depths are based on A, B, C and C-80 soil types as described in O.S.H.A.'s 29 CFR Part 1926 Subpart P, October 31, 1989 with Type A not exceeding 25 PSF per foot of depth, Type B not exceeding 45 PSF per foot of depth, Type C not exceeding 60 PSF per foot of depth and Type C-80 not exceeding 80 PSF per foot of depth. Determine actual soil pressure and consult manufacturers Tabulated Data prior to each use.

Height Adapters



Height Adapters

Since no one project is the same as another, GME has designed multiple standard Height Adapters to fit the needs and equipment of the project. All Standard Height Adapters are designed to be used with one trench shield, providing up to 10' of vertical pipe clearance, or two stacked trench shields (top trench box is to be inverted) providing up to 13' of vertical clearance while enabling up to 20' of horizontal width. Height Adapters from GME offer end users the extended vertical pipe clearance for projects that require the installation of large diameter pipes & vaults, as well as providing the working clearance desired for boring projects and pits.

Type 1, 2, 3, & 4

These Height Adapters are designed and engineered to have interchangeable extensions pieces with each other, providing up to 13' of vertical clearance when using stacked 20' long trench boxes to a depth of 14' in C-60 soils.

Type 5

Engineered for projects that require a little more trench shield length. Using the Type 5 Height Adapter, 30' long trench shields can be used to a depth of 14' in C-60 soils, while still providing up to 13' of vertical clearance.

Type 6

Similar to the Type 5, the Type 6 Height adapters are designed for uses at greater depths. With the Type 6 Height Adapters are able to go to a depth of 18' in C-60 Soils, when paired with 30' long trench boxes.

Type 7

For projects that require a mix of depth and large trench shields. With the Type 7 Height Adapters, 30' long trench shields are able to achieve depths of up to 25' in C-60 soils.

Universal Height Adapter

The Universal Height Adapter is designed to fit on a multitude of trench shield collar set-ups. With its design, the Universal Height Adapter provides 10' of vertical clearance. Featuring bolt-on extensions, the Universal Height Adapter is able to provide up to 20' of internal width!



Spreaders and Sheeting

Spreaders

8DS

The 8DS Spreaders from GME, are 8" sch. 80 spreader pipe built to be used with the 4", 6", and 8" trench shields. Each set of 8DS Spreaders includes 2" diameter pins and keepers.

5DS

The 5DS Spreaders from GME, are 5" sch. 80 spreader pipe built to be used with the 3M, 4L, and MH trench shields. Pins and keepers are included.

3SQ

The 3SQ Spreaders from GME, are 3" x 3" x 3/16" tubes built to be used with the 3L trench shields. All attaching hardware is included.

8DS - 8" Sch. 80 Pipe			5DS - 5" Sch. 80 Pipe			3SQ - 3" Square Tubing		
Model	Inside Width	Weight (lbs.)	Model	Inside Width	Weight (lbs.)	Model	Inside Width	Weight (lbs.)
8DS24	24"	387	5DS24	24"	186	3SQ24	24"	77
8DS30	30"	474	5DS30	30"	228	3SQ30	30"	88
8DS36	36"	561	5DS36	36"	269	3SQ36	36"	100
8DS42	42"	647	5DS42	42"	311	3SQ42	42"	111
8DS48	48"	734	5DS48	48"	352	3SQ48	48"	123
8DS60	60"	908	5DS60	60"	436	3SQ60	60"	146
8DS72	72"	1081	5DS72	72"	519	3SQ72	72"	168
8DS84	84"	1255	5DS84	84"	602	3SQ84	84"	192
8DS96	96"	1428	5DS96	96"	768	3SQ96	96"	216
8DS108	108"	1602	5DS108	108"	851			
8DS120	120"	1776						
8DS132	132"	1949						
8DS144	144"	2123						

Additional sizes are also available



Model	Length	Weight (lbs.)
HDOS-120	10'	450
HDOS-144	12'	540
HDOS-168	14'	630
HDOS-216	18'	810
HDOS-240	20'	900

Additional sizes are also available

Overlap Sheeting

Designed to be used as a means of temporary closing off an open side of a trench shield project, the GME Overlap Sheeting is easy to install. Designed to overlap instead of interlock, the GME Overlap Sheeting is 3/8" thick and available in lengths from 10' to 24'.

Pit Kits and Custom Products



Pit Kits

Designed to allow trench shield panels to connect together without the need of spreader pipes or shield modification, the GME Pit Kit Corner Connectors offer users the ability to further utilize their fleet by having trench shield panels act as end panels. The GME Pit Kits are designed to allow for either horizontal or vertical collar pin holes.

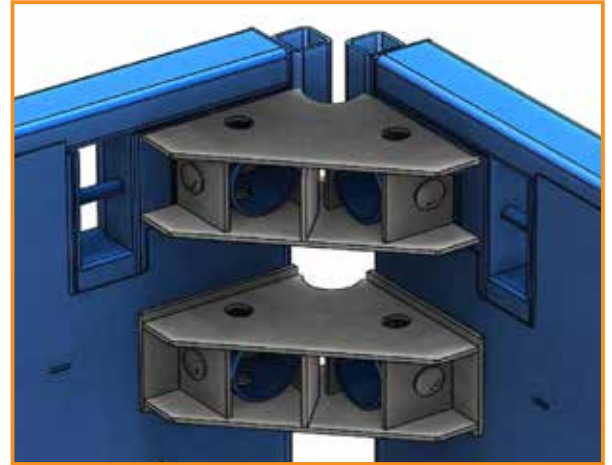

Custom Products

With 150,000+ square feet of available manufacturing space, coupled with a highly skilled labor force, a dedicated R&D team and a desire to provide customers with solutions, GME takes pride in custom projects. Whether they be a custom tweak to an otherwise standard trench shield or a completely new take on how to increase job-site productivity, GME has the ability and know how to make it work!



Job site photos are strictly intended for general product information only and may not comply with all applicable safety standards. Always refer to manufacturers' specific tabulated data, O.S.H.A. 29 CFR 1926 Subpart P for excavations, and all applicable safety standards prior to each use.

How To Size a Trench Shield

How to size a trench shield

Below are eight essential questions to be answered to properly determine the model, size, and spreaders needed for a trench shield. The answers to these questions will allow the user of the trench shield to not only have the correct trench shield for the project, but also enable them to minimize site restoration costs.

1. What type of project is it? _____
Sewer, Repair, Water main, Manhole, Bore pit, etc... The type of project may dictate the style of trench shield that will need to be used. If the project is a bore pit, smaller shields may be used, but they may require a height adapter to provide the vertical clearance need for the bore machine.
2. Depth of cut? _____
Knowing the required depth of the project will shed light a few items like, how tall the shield(s) need to be, is stacking gear required and how thick the sidewalls will need to be.
3. Soil Conditions or type? _____
What is the soil like? Dry, wet, standing water, rocky...?
4. Outside diameter of pipe\structure (at largest point)? _____
To minimize the amount of soil to remove, and to provide adequate working room, it is recommended that a trench shield be 12" wider than pipe\structure.
5. Overall bucket width (including side cutters)? _____
In cases that the pipe or structure is small, the overall width of the excavator bucket can be used to gauge what the internal width of the system should be. It is recommended that inside width of trench shield be 12" wider than bucket width.
6. Pipe\Structure length? _____
It is recommended that a trench shield be 4' longer. This allows for the pipe or structure to be lowered directly into the shield instead of trying to snake the pipe or structure between smaller shields. This will protect the workers when they are working on the end of the pipe in case of a cave-in.
7. Lift capacity of machine? _____
1.5 times the overall weight of the trench shield plus spreaders, at 20' (6m), at grade level. This assures that not only will the machine be able to set the trench shield system, but it also should be able to remove the system as well.
8. Minimum vertical pipe clearance needed? _____
Space from top of pipe\structure to bottom of excavation.

PRODUCER OF THE WORLD'S MOST COMPLETE LINE OF TRENCH SHORING & SHIELDING EQUIPMENT

Slide Rail Shoring



Lite Shields



Height Adapters



AEX Shields



MD Brace System



Hydraulic Shoring



Bedding Boxes



Hydraulic Shields



Exit Grids



Port-a-Bridges

